

Specifications

MODEL:		PT130	PT155	PT180
INPUT POWER				
Input frequency	50 or 60 Hz auto-sensing			
Power factor	Near unity			
Input voltage operating range	170 - 277 VAC, single-phase			
OUTPUT POWER				
Output power characteristics	Sinusoidal, <2% total harmonic distortion			
Voltage regulation	+/- 2% for entire input voltage range			
Output voltage*	User selected 208 V, 220/110 V, 230/115 V, 240/120 V, single-phase			
Output frequency	User selected 50 Hz or 60 Hz, +/- 0.05%			
Rated output current	30A	55A	80A	
Rated KVA (220V in, 240V out)**	7.2 KVA	13.2 KVA	19.2 KVA	
GENERAL				
Efficiency	95% typical			
Ambient temperature range***	-10 -40 C			
Storage temperature	-20 -60 C			
Connections	Hard wired, terminal blocks			
Enclosure	Powder coated aluminum, indoor Type 1, wall mount			
Weight	Converter module:	85 lb.	145 lb.	185 lb.
	Transformer module:	150 lb.	270 lb.	300 lb.
Dimensions H x W x D	Converter module:	20 x 14 x 13 in.	24 x 19 x 13 in.	31 x 26 x 13 in.
	Transformer module:	21 x 20 x 13 in.	21 x 20 x 15 in.	21 x 20 x 15 in.

*Dual voltage available only when equipped with optional isolation transformer **De-rate linearly as input voltage decreases ***Extended temperature range models available Specifications subject to change without notice



Block Diagram

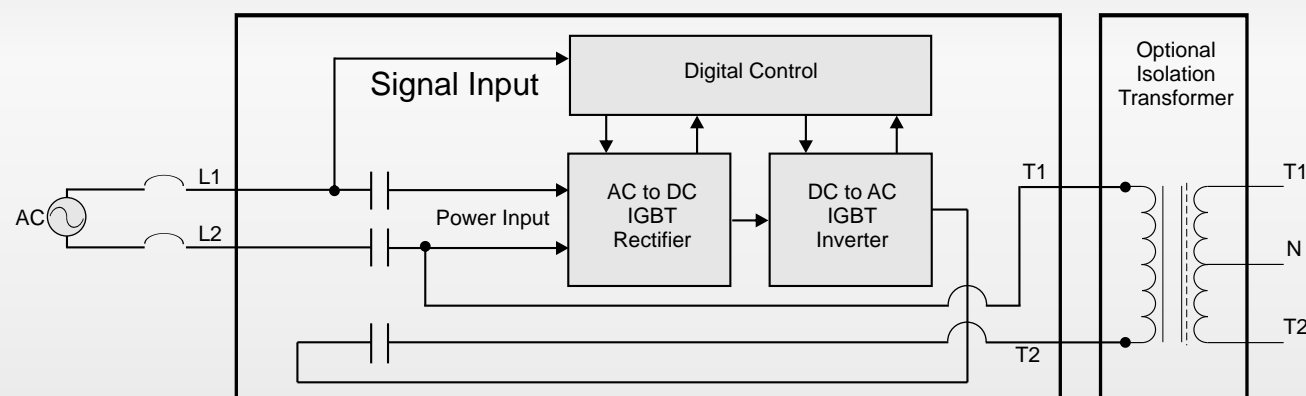

Rugged
Reliable
Affordable

Protects sensitive
electrical equipment
even in the
harshest power
quality environment.



PHASETEC
DIGITAL POWER CONDITIONERS™

Rugged

Reliable

Affordable

Common Power Quality Problems

- Spikes
- Surges
- Sags
- Brownouts
- Power Outages
- Electromagnetic Interference
- Transients
- Harmonics



Power Quality

As sophisticated electronic equipment becomes more prevalent in homes, industrial and commercial settings, clean, well regulated electric power is essential. Events such as voltage sags, surges, transients and harmonic distortion cause sensitive equipment to malfunction, costing the economy billions of dollars annually.

PhaseTec™ Digital Power Conditioners

provide the ultimate power quality to protect the most sensitive electrical equipment. Employing the latest developments in power switching electronics & DSP control, it exerts total control over power quality and completely isolates equipment from the original power source. PhaseTec digital power conditioners are designed to safely operate electrical equipment in the harshest power quality environments.

What make PhaseTec Power Conditioners different?

Most other power conditioners are transformer based technologies that provide voltage regulation and some degree of protection from other adverse power events. PhaseTec employs double IGBT conversion for the most advanced power conditioning available. This process converts the incoming AC power to DC, then rebuilds a new AC voltage for exceptionally stable, clean power. The double conversion topology also provides total isolation from power problems that can plague AC power mains. With a wide input voltage range, user selected output voltages and frequency conversion capabilities, PhaseTec power conditioners can operate anywhere in the world.



Models successfully deployed in military war theater applications.

A Versatile Solution for Power Quality Problems

Even though PhaseTec power conditioners are built using the latest advances in solid state power switching technology, their compact, rugged design makes them suitable for just about any application—from controlled environment IT rooms to mobile battlefield applications. PhaseTec is also effective at stabilizing voltage and frequency, and eliminating harmonics from generator power sources. With electronic power factor correction on the input module there is no need to oversize the generator.

PhaseTec Features

- Accepts a wide range of input voltage while maintaining tight output voltage regulation
- Four user selected output voltages to operate a wide range of equipment
- 50 or 60 Hz auto-sensing input frequency and user selected output of 50 or 60 Hz allows for frequency conversion and operation anywhere in the world
- Double IGBT conversion isolates even the most sensitive equipment from dips, sags, surges, transients and harmonics
- Electronic power factor correction on the input module protects upstream equipment from harmonic distortion and complies with the IEEE 519 standard for harmonics
- High momentary overload capacity for demanding applications
- Optional isolation transformer provides dual voltage output and protection from common mode noise
- Designed with 3-stage LC filtering and extensive shielding to reduce EMI/RFI
- Models available tested to MIL-STD 461E for Ground Army Operations (a military standard for electromagnetic interference) **
- Optional backlit display provides text messages for operating status and troubleshooting codes
- Compact size and rugged design suitable for mobile applications in harsh environments
- UL listed in the USA and Canada

** Test results on file with Phase Technologies, LLC

PhaseTec's double-conversion process provides COMPLETE PROTECTION by rebuilding the AC voltage.

