



PT Series Power Supplies

OPERATION & INSTALLATION MANUAL

SAFETY MESSAGES AND WARNINGS

To ensure safe and reliable operation of the AquaPhase AP Series pump converter, it is important to carefully read this manual, and to read and observe all warning labels attached to the drive before installing the equipment. Please follow all instructions exactly, and keep this manual with the equipment at all times for quick and easy reference.

Definitions of Warning Signs and Symbols

 **CAUTION:** Indicates a potentially hazardous situation that could result in injury or damage to the product.

 **WARNING:** Indicates a potentially hazardous situation that could result in serious injury or death.

 **HIGH VOLTAGE:** Indicates high voltage. The voltage associated with the procedures or operations referenced could result in serious injury or death. Use caution and follow instructions carefully.

READ THESE WARNINGS BEFORE INSTALLING OR OPERATING THE EQUIPMENT!

 **WARNING:** Risk of electric shock. More than one disconnect switch is required to de-energize the equipment before servicing.

 **WARNING:** Risk of electric shock. De-energize the unit by disconnecting all incoming sources of power, then wait 30 minutes for internal charges to dissipate before servicing the equipment.

 **HIGH VOLTAGE:** This equipment is connected to line voltages that can create a potentially hazardous situation. Electric shock could result in serious injury or death. This device should be installed only by trained, licensed and qualified personnel. Follow instructions carefully and observe all warnings.

 **WARNING:** This equipment should be installed and serviced by qualified personnel familiar with the type of equipment and experienced in working with dangerous voltages.

- ⚠ WARNING:** Installation of this equipment must comply with the National Electrical Code (NEC) and all applicable local codes. Failure to observe and comply with these codes could result in risk of electric shock, fire or damage to the equipment.
- ⚠ WARNING:** Control Terminals A, B, C, are rated at 240V. Disconnect power to the main input terminals before servicing these circuits.
- ⚠ CAUTION:** Circuit breakers or fuses, proper ground circuits, disconnects and other safety equipment and their proper installation are not provided by Phase Technologies, LLC, and are the responsibility of the end user.
- ⚠ CAUTION:** Failure to maintain adequate clearance may lead to overheating of the unit and cause damage or fire.
- ⚠ WARNING:** “Suitable for use in a circuit capable of delivering not more than 5 kA RMS symmetrical amperes, 240 V maximum.” For all models except PT3160.
- ⚠ WARNING:** “Suitable for use in a circuit capable of delivering not more than 10 kA RMS symmetrical amperes, 240 V maximum.” For model PT3160.
- ⚠ WARNING:** Wire used within the motor circuit and all field wiring terminals must be rated for at least 60 C.
- ⚠ WARNING:** Use wire size suitable for Class 1 circuits.
- ⚠ WARNING:** Input power connections should be made by a qualified electrician into a nominal 240V circuit with adequate current carrying capacity. Branch circuit protection to the unit should be provided by appropriate size fuses or a 2 pole, linked circuit breaker. Circuit breaker and fuse ratings for each model are listed in Table 3.
- ⚠ CAUTION:** Use 600 V vinyl-sheathed wire or equivalent. The voltage drop of the leads needs to be considered in determining wire size. Voltage drop is dependent on wire length and gauge. Use Copper Or Aluminum Conductors.
- ⚠ CAUTION:** Wires fastened to the terminal blocks shall be secured by tightening the terminal screws to a torque value listed in Table 4.

- ⚠ CAUTION:** The input wire gauge must be sized to accommodate the single-phase input current, which will be significantly larger than the three-phase output current to the load.
- ⚠ CAUTION:** The maximum wire gauge for the input terminals is listed in Table 4.
- ⚠ CAUTION:** Never allow bare wire to contact the metal surfaces.
- ⚠ CAUTION:** Never connect AC main power to the output terminals T1, T2, and T3.
- ⚠ WARNING:** Under certain conditions, the motor may automatically restart after a trip has stopped it. Make sure power to the drive has been disconnected before approaching or servicing the equipment. Otherwise, serious injury may occur.

OVERVIEW

Congratulations on your purchase of a PT Series power supply! This device features the latest advances in solid state power switching electronics to provide outstanding performance. It provides clean, balanced power for operating a wide variety of electrical equipment. The PT Series is available in a variety of configurations and sizes to fit your power needs up to 66 KVA.

KEY FEATURES AND BENEFITS:

- Clean, balanced power under all load conditions for even the most demanding applications
- Electronic power factor correction on the input module for efficient, utility-friendly operation
- IEEE 519 compliant
- Sinusoidal output voltage allows operation of all types of sensitive equipment
- Protects operated equipment from over-voltage, under-voltage and other adverse events
- 97% efficiency typical
- Simple to configure and install
- Optional Motor Starter feature includes starter and overload protection for single motor loads
- Remote ON/OFF switching capability standard on all models
- EMI filter options available to reduce both conducted and emitted noise
- Optional plasma display for 2 line, 32 character text display of status indicators and trouble shooting codes
- New compact design in wall mounted enclosures
- Outdoor rainproof enclosures available

LIMITED WARRANTY

Phase Technologies equipment is warranted against defects in material and workmanship for a period of one year. This warranty covers both parts and labor for one year from the date of purchase by the original owner. Phase Technologies will repair or replace (at our option), at no charge, any part(s) found to be faulty during the warranty period specified. The warranty repairs must be performed by/at a Phase Technologies Authorized Service Center or at Phase Technologies LLC, Rapid City, SD 57703.

Obligations of the Original Owner

1. The original Bill of Sale must be presented in order to obtain “in-warranty” service.
2. Transportation to Phase Technologies or an Authorized Service Center is the responsibility of the original purchaser. Return transportation is provided by Phase Technologies.
3. Installations must comply with all national and local electrical codes.

Exclusions of the Warranty

This warranty does not cover any of the following: accident, misuse, fire, flood, and other acts of God, nor any contingencies beyond the control of Phase Technologies, LLC, including water damage, incorrect line voltage, improper installation, missing or altered serial numbers, and service performed by an unauthorized facility. Phase Technologies’ liability for any damages caused in association with the use of Phase Technologies’ equipment shall be limited to the repair or replacement only of the Phase Technologies’ equipment. No person, agent, distributor, dealer, or company is authorized to modify, alter, or change the design of this merchandise without express written approval of Phase Technologies, LLC.

INSTALLATIONS MUST COMPLY WITH ALL NATIONAL AND LOCAL ELECTRICAL CODE REQUIREMENTS.

TABLE OF CONTENTS

Safety Messages and Warnings.....	ii
Overview.....	v
Warranty.....	vi
Section 1: INTRODUCTION	
Figure 1 Block Diagram	1
Model Number Information.....	2
Section 2: INSTALLATION	
Mounting the Unit.....	3
Electrical Connections.....	3
Connecting to Field Wiring Terminals.....	4
Figure 2 Field Wiring Terminals.....	4
Field Wiring for Parallel Units	4
Figure 3 Parallel Systems.....	5
Procedure for Installing Parallel Systems	5
Figure 4 PT Series Parallel Field Wiring Diagram.....	6
Table 1 Field Wiring Terminals.....	7
General Wiring Considerations.....	7
Table 2 Field Wiring Terminal Specifications.....	8
Table 3 Input Circuit Breaker and Fuse Ratings.....	9
Input Power Source Considerations.....	9
Figure 5 Power Source Configurations.....	10
Section 3: TYPICAL SYSTEM CONFIGURATIONS	
Power Supply Configuration.....	11
Figure 6 Power Supply Configuration.....	12
Motor Starter Configuration.....	13
Figure 7 Motor Starter Configuration.....	14
Remote ON/OFF Control.....	15
Figure 8 Motor Starter with Remote ON/OFF.....	16
Section 4: OPERATION	17
ON/OFF Options	17
Status Indicators.....	18
Section 5: MOTOR OVERLOAD RELAY INFORMATION	19

Continued on next page

Table of Contents, continued ...

Section 6: STATUS INDICATORS AND TROUBLESHOOTING.....20
General Troubleshooting Tips.....20
Table 4 Status Indicators.....22

Section 7: FEATURES AND SPECIFICATIONS.....24
Features and Specifications.....24
Table 5 Specifications.....25
Table 6 Fuses.....25

©Copyright. All rights reserved. All contents are property of Phase Technologies, LLC.

No portion of this publication or its contents may be duplicated by any means, electronic or otherwise, without the express written consent of Phase Technologies, LLC.

Contact:
Phase Technologies, LLC
3620 Homestead Street
Rapid City, SD 57703
www.phasetechnologies.com

SECTION 1: INTRODUCTION

The diagram in Figure 1 illustrates the basic design of a PT Series power supply with three-phase output:

Figure 1 Phase Perfect Block Diagram

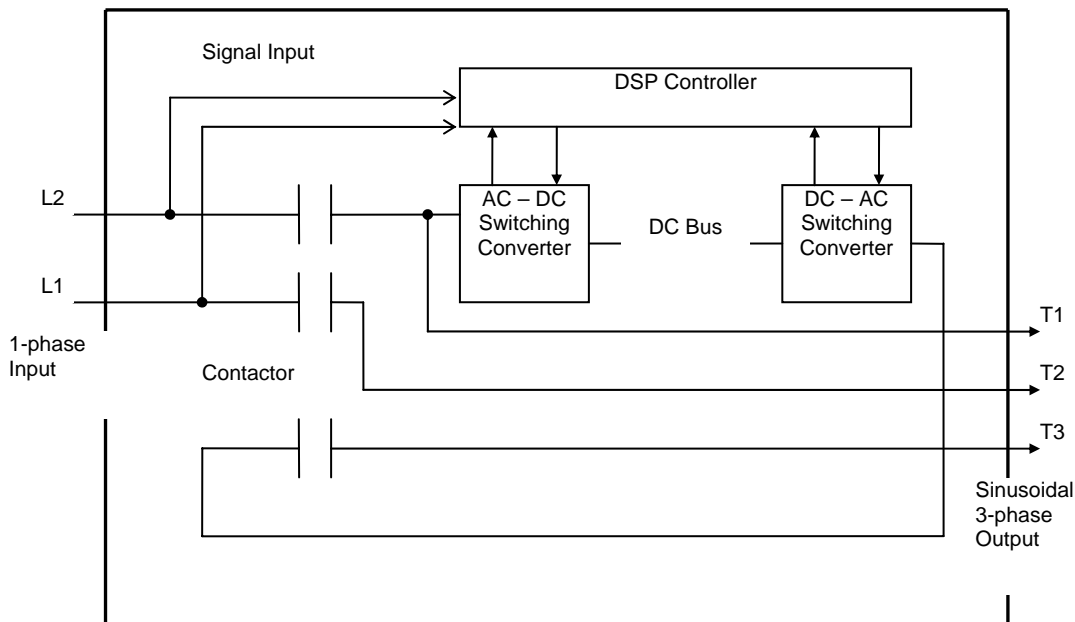

The input module takes power from the input lines and charges a DC bus. The output module then draws power from the DC bus to generate an AC voltage referenced to L2 of the input, which passes through the unit.

In a system with three-phase output, L1 and L2 of the single-phase input pass directly through the phase converter to provide two legs of the three-phase output. A manufactured phase is combined with the two input legs to produce three-phase output power. Hence, **the three-phase output voltage will be equal to the single-phase input voltage** (e.g. a 240 VAC single-phase input will produce 240 VAC three-phase output).

The three-phase output is delta configured. While the phase-to-phase voltages are equal, the phase-to-ground voltages are not equal. Phase-to-ground voltage for both T1 and T2 should be approximately 120V. Phase-to-ground for T3 should be approximately 208V. For three-phase loads that are designed for delta connection, the load derives its voltage phase-to-phase, so the phase-to-ground voltage should not affect the operation of the equipment. **If the connected load has a neutral connection and requires wye configured power, the output of the phase converter must be passed through a delta-to-wye isolation transformer before connection to the load.**

PT Series Model Number Information

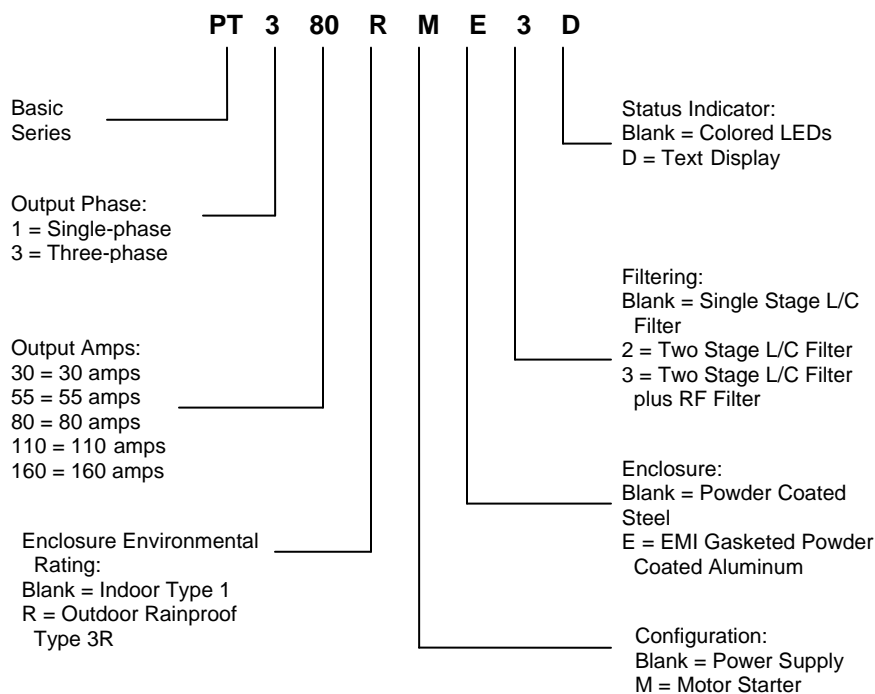

SECTION 2: INSTALLATION

SECTION 2: INSTALLATION

Models are available in Type 1 indoor or Type 3R rain proof enclosures. The unit should be securely mounted to a solid, non-flammable vertical surface. Choose a location that minimizes the introduction of dust and other contaminants into ventilation openings.

Mounting the Unit

Properly locating the unit is important to the performance and normal operating life of the unit. The unit should be installed in a location free from:

- Excessive dirt and dust
- Corrosive gases or liquids
- Excessive vibration
- Airborne metallic particles

It is important that the unit be located away from excessive dirt and dust. It should be securely fastened to a solid, non-flammable vertical surface using the mounting brackets provided with the unit. Make sure the mounting surface is capable of bearing the weight of the unit. Weights for each model can be found in the *Specification Table* of this document. Elevating the unit well above the ground will help to reduce the introduction of dust and contaminants into the enclosure.

Larger models are provided with lifting eye bolts on the enclosure. **CABLES, STRAPS OR CHAINS USED FOR LIFTING THESE UNITS MUST BE ATTACHED ONLY TO THE PROVIDED BRACKETS.**

In order to provide proper ventilation, do not obstruct the open space around the enclosure. In order to maintain air circulation for cooling, minimum clearance must be 2 inches on each side, and 6 inches top and bottom. Make sure air intake and exhaust openings are not obstructed. If the unit is mounted in a small room, cabinet or building, make certain there is adequate ventilation to provide cooling for the unit.

Electrical Connections

This Section provides a description of general wiring considerations, as well as diagrams of typical input power wiring configurations, and discusses important considerations involved in input wiring from various sources.

Electrical connections to the unit are made behind the front door of the enclosure, as described in the section below, *Connecting to Field Wiring Terminals*. Terminal blocks for connecting wires are located on a panel inside the enclosure of the unit. Figure 2 below illustrates typical wiring connections found on the panel.

Connecting to Field Wiring Terminals

Open the front cover of the enclosure to gain access to the wiring panel. The field wiring terminals of a typical unit are illustrated in Figure 2:

Figure 2 Field Wiring Terminals

Note: ABC CONTROL Terminals on parallel systems are located inside the Master Unit enclosure, not in the Junction Box

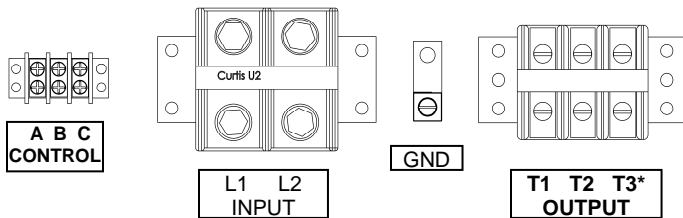

Field Wiring for Parallel Units

Models of the PT Series with output of 55 amps and 80 amps can be wired in parallel for output power double that of each individual unit. Parallel units are configured as a master and a slave connected to each other by conduit that contains control wires.

When combined, the two units are given a different model number to reflect the increased input and output power levels. For example, two models PT380 connected in parallel would become a model PT3160. Parallel units are connected with all control wires, and the two enclosures physically attached in the factory, then shipped as one unit.

A separate junction box containing input and output field wiring terminals is shipped with the unit. The junction box provides a common point of connection for the input and output output wires to field wired terminals.

CAUTION! The output wires of two systems in parallel must always be connected to a common point.

Figure 3 depicts a typical parallel system.

Figure 3 Parallel Systems

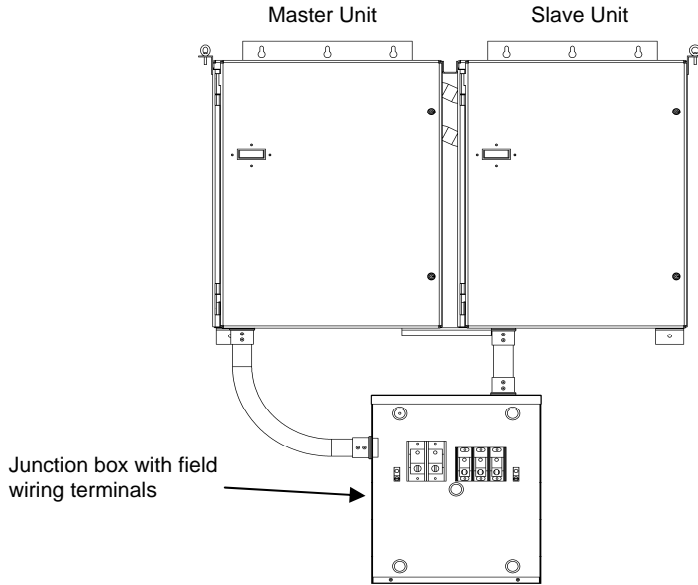

Procedure for Installing Parallel Systems

1. Mount and securely fasten the PT Series units on a wall or suitable vertical surface. See Section 2 *Mounting the Unit* for complete details on mounting.
2. Attach suitable conduit to the opening in the underside of each PT Series unit, then to the Junction Box as depicted in Figure 3.
3. Fasten the Junction Box securely to the wall.
4. Inside each PT Series enclosure is a pigtail of input and output wires. Pull the wires through the conduit into the Junction Box.
5. Each input and output wire is clearly marked with a label (L1, T1, etc.) and color coded to a match a corresponding labeled and color coded field wiring terminal. Connect each wire to the **top side** of the appropriate terminal and torque to the value in Table 2.
6. The input wires and output wires from the PT Series units must be connected in parallel. For example, the wires labeled *L1* from each PT Series unit must both be connected to the same terminal in the Junction Box labeled *L1*. See Figure 4 for a

schematic representation of field wiring for parallel units. **CAUTION! Never connect unlike wires from the PT Series units to the same terminal in the Junction Box.**

Otherwise, the units may be severely damaged, and the warranty will be void.

7. Pull source input wires and output wires to the load through conduit into the Junction Box and connect to the **bottom side** of the appropriate field wiring terminals. Torque to values in Table 2.

Figure 4 PT SERIES PARALLEL FIELD WIRING DIAGRAM

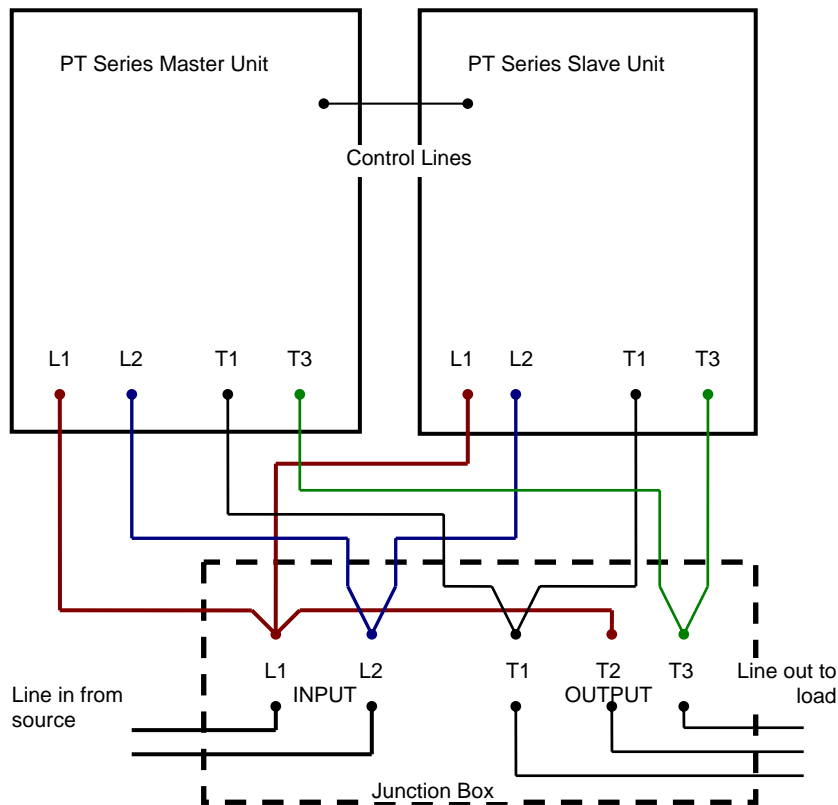

Field wiring terminations are made on terminal blocks in the Junction Box

Table 1 Field Wiring Terminals

TERMINAL	FUNCTION	COMMENTS
GND	Earth ground connection for source and load	
L1, L2	Single-phase input terminals	See <i>Input Power Source Considerations</i> for proper connection
CONTROL A B C	Connection to control the unit from a remote switch Also enables the optional motor overload relay*	Shipped from factory with jumper from A to B Motor overload relay is de-activated if control jumper is connected from B to C
T1, T2,T3	Three-phase output terminals	T3 is the manufactured phase

*The solid state overload relay is present only when the unit is ordered and equipped with the optional Motor Starter feature. The Motor Starter option allows the unit to start and protect single motor loads. **There is no need to move the jumper from A-B to B-C if the converter is not equipped with the optional Motor Starter.**

GENERAL WIRING CONSIDERATIONS

Installations must comply with all national and local electrical code requirements. General Wiring Considerations Include:

1. All models except PT3160 are suitable for use in a circuit capable of delivering not more than 5 kA RMS symmetrical amperes, 240 V maximum.
2. Model PT3160 is suitable for use in a circuit capable of delivering not more than 10 kA RMS symmetrical amperes, 240 V maximum.
3. Use 600 V vinyl-sheathed wire or equivalent. The voltage drop of the leads needs to be considered in determining wire size. Voltage drop is dependent on wire length and gauge.
4. Wire used within the motor circuit and all field wiring terminals must be rated for at least 60 C.
5. Wires fastened to the terminal blocks shall be secured by tightening the terminal screws to a torque value listed in Table 2.
6. Use wire size suitable for Class 1 circuits.
7. For models with three-phase output, the input wire gauge must be sized to accommodate the single-phase input current, which will be approximately 1.8 times the total three-

- phase output current to the load(s). For example, if the output load is 20 Hp, the three-phase output current will be approximately 54 amps, and the single-phase input current will be approximately 88 amps.
8. The maximum wire gauge for the input terminals is listed in Table 2.
 9. Never allow bare wire to contact the metal surfaces.
 10. Never connect AC main power to the output terminals T1, T2, and T3.
 11. Input power connections should be made by a qualified electrician into a 208V or 240 V circuit with adequate current carrying capacity and the appropriate sized breaker. Branch circuit protection to the phase converter should be provided by appropriate size fuses or a 2 pole, linked circuit breaker. Circuit breaker and fuse ratings for each model are listed in Table 3.

Table 2 Field Wiring Terminal Specifications

Model	PT3160		PT3110	
	Source Line Side	PT Unit Side	Source Line Side	PT Unit Side
Input Terminals				
Tightening torque	375 in. lbs	192 in. lbs	275 in. lbs	192 in. lbs
Max. wire size	500kcmil – 4 AWG	3/8 – 16 Stud	350kcmil – 6 AWG	3/8 – 16 Stud
Output Terminals	Load Side	PT Unit Side	Load Side	PT Unit Side
Tightening torque	375 in. lbs	192 in. lbs	120 in. lbs (2/0-6 AWG) 40 in. lbs (8AWG) 35 in. lbs (10-14 AWG)	61 in. lbs
Max. Wire size	500kcmil – 4 AWG	3/8 – 16 Stud	2/0 – 14 AWG	1/4 - 20 Stud

Model	PT380	PT355	PT330
Input Terminals			
Tightening torque	275 in.-lb.	50 in.-lb.	16 in.-lb.
Max. wire size	6 AWG - 250 MCM	6 - 1/0 AWG	14 - 6 AWG
Output Terminals			
Tightening torque	50 in.-lb.	45 in.-lb (4-6 AWG) 40 in.-lb. (8AWG) 35 in.-lb. (10-16 AWG)	16 in.-lb.
Max. Wire size	6 - 1/0 AWG	16 – 4 AWG	14 - 6 AWG

Table 3 Input Circuit Breaker and Fuse Ratings

Model	PT3160	PT3110	PT380	PT355	PT330
Maximum fuse rating, Class RK5	400	250	200	125	70
Maximum fuse rating, Class 200	400	250	200	125	70
Maximum circuit breaker rating, amps	400	250	200	125	70

Input Power Source Considerations

The unit can be operated from most input power sources ranging from 187 VAC to 255 VAC. However, specific input wiring issues must be considered when wiring to three-phase input sources.

⚠ WARNING! Incorrect L1 and L2 wiring from some three-phase sources can result in high phase-to-ground voltage. These considerations are outlined in Figure 5 *Power Source Configurations*:

Figure 5 Power Source Configurations

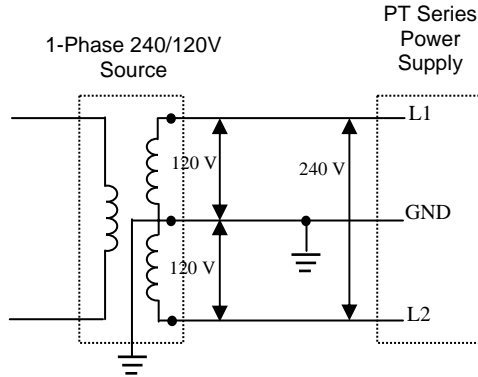

Single-phase, 120/240V, 3 Wire
 In most installations, single-phase 240V input power will be taken from a 240/120V center tap source. Connect L1 and L2 to the input terminals.

WARNING!
Three-phase, 240/120V, Delta
 In some situations, single-phase 240V input power may be derived from a three-phase source as illustrated to the left. Caution must be exercised if using such a source for power input to the unit. Power should only be derived from legs 1 & 2, with a center ground, as illustrated. Power derived from legs 2 & 3, or 3 & 1, may result in output phase-to-ground voltage well above 200V. To avoid potentially hazardous voltage, always verify the phase-to-ground voltage for the L1 and L2 inputs is approximately 120V.

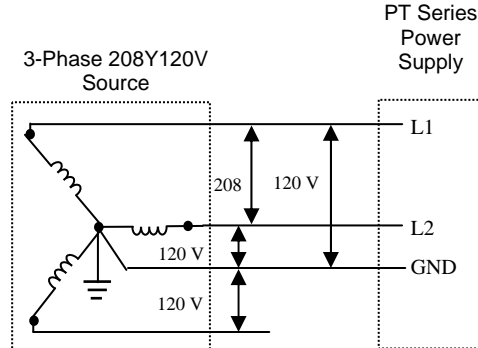
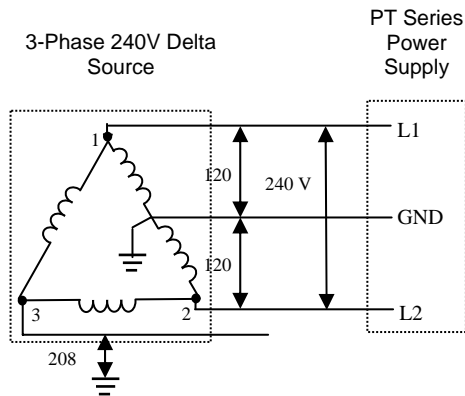

WARNING!
Three-phase, 208Y/120V
 Single-phase 208V input power can be taken from two legs of a three-phase grounded-wye source. There are two possible ways to connect L1 and L2 to the unit from any two legs. If the unit is connected incorrectly, the voltage from output line T3 to ground will be over 240V. Reversing L1 and L2 on the input should lower the T3 to ground voltage to 120V.

Section 3: TYPICAL SYSTEM CONFIGURATIONS

A PT Series power supply is designed to simplify installation, to provide maximum versatility, and to eliminate or minimize the need for external electrical components and related costs. The output voltage of the unit is sinusoidal with very little harmonic content, eliminating the need for output filtering that would often be required for a variable frequency drive (VFD). With little distortion of the input current, the unit does not require input filtering to comply with IEE519, the standard that sets limits for distortion of utility mains power. When equipped with the optional Motor Starter, it can start and protect a motor load, eliminating the need for a motor starter panel in many single-motor applications. All types of equipment, including inductive, resistive, and capacitive loads can be safely powered by a PT Series power supply.

Three typical installations are diagrammed and explained below:

- A power supply configuration for use in powering multiple loads
- A motor starter configuration for use with a single-motor load
- A configuration in which a remote switch turns the unit ON/OFF

Power Supply Configuration

The unit can be configured as a power supply to provide power to multiple loads of any type, including inductive, resistive, and capacitive loads. If the unit is equipped with the **optional** Motor Starter feature, the jumper on the Control Terminals should be set to connect B to C for power supply operation. Connecting B to C on the Control Terminal will disable the motor overload relay when it is present.

CAUTION! The wire connecting A to C at the top of the Control Terminal strip is **NOT** a jumper, and should **NOT** be removed.

Separate, properly sized motor starters should be provided for each motor load to be powered. The power supply configuration used to power multiple motor loads or loads with integrated controls is illustrated in Figure 6:

Figure 6 Power Supply Configuration

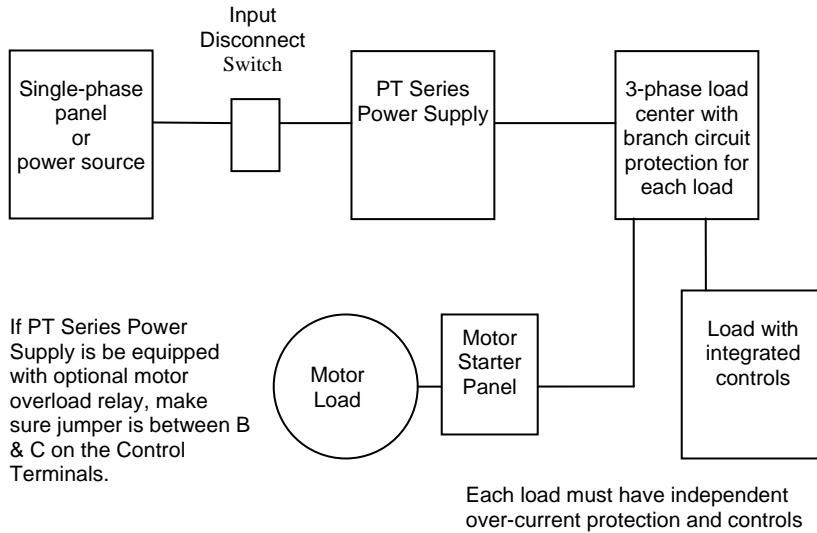

Follow this procedure when wiring the unit as a power supply to provide three-phase power to multiple loads or to loads with integrated controls:

1. Verify that no input power is connected to the unit by turning the input disconnect to OFF, then lock and tag it.
2. Open the front cover to gain access to the wiring terminals. See the *Section 2, Connecting to Field Wiring Terminals*, for a drawing illustrating the wiring terminals.
3. If the unit is equipped with the optional Motor Starter, it is shipped from the factory with a metal jumper connecting Control Terminals A and B. Remove the metal jumper between terminals A and B, then install the jumper between terminals B and C.

CAUTION! The wire connecting A to C at the top of the Control Terminal is **NOT** a jumper, and should **NOT** be removed.

4. Placing the metal jumper between terminals B and C on the Control Terminal will disable the optional motor overload relay.

5. Connect input power to the unit from an appropriate single-phase circuit. See the Section 2, *Input Power Source Considerations*, for additional information.
6. Before energizing the input power, measure the source voltage. Phase-to-phase voltage must be within the input range of 187-260VAC, and the phase-to-ground voltage should be half this value.
7. Energize the unit before any loads are connected to the output and measure the output phase-to-phase voltages to ensure they are within the specified range. Because the three-phase output is delta-configured three-phase, the output phase-to-ground voltages will not be equal. T3-to-ground voltage will be higher than T1 or T2 to ground.
8. Turn the unit OFF by means of the input disconnect, lock and tag it, then wait at least 30 minutes for any internal charges to dissipate.
9. Connect the output wires to the output terminals. Torque the terminal screws to the values listed in Table 2 *Field Wiring Terminal Specifications*.
10. Close and latch front cover.
11. Turn the unit ON from the disconnect switch. Power will be available to the load circuits after an approximately five to eight second delay. Check any three-phase motor loads for correct rotation. If the motor rotation is incorrect, reverse any two of the three output power leads to that motor.
12. A low power remote switch may be wired into the Control Terminal of the unit to provide remote ON/OFF switching of the unit.

⚠ WARNING! When the converter is turned OFF using a remote switch on the Control Terminals, dangerous voltage is still present on the input lines, inside the enclosure and on certain output lines to ground. Never open the enclosure or perform maintenance on the unit and its connected loads when the input disconnect switch is in the ON position.

Motor Starter Configuration

With the Motor Starter option, a PT Series power supply can be used to start and protect a motor load, eliminating the need for a three-phase starter panel. An appropriate sized disconnect must be installed on the input side of the unit. The optional overload relay can be adjusted for motor ratings up to the rated HP capacity of the converter. The motor

Figure 7 Motor Starter Configuration

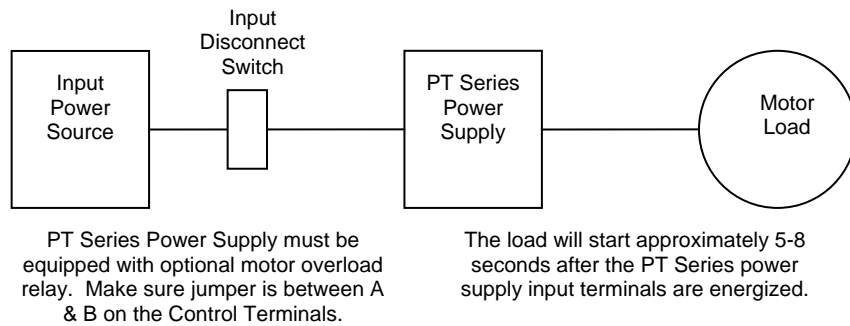

starter configuration used to power a single motor is illustrated in Figure7:

Follow this procedure when wiring a PT Series unit as a motor starter to power a single motor:

1. Verify that no input power is connected to the unit by turning the input disconnect to OFF, then lock and tag it.
2. Open the front cover to gain access to the wiring terminals. See the Section 2, *Connecting to Field Wiring Terminals*, for a drawing illustrating the wiring terminals.
3. Verify that Control Terminals A and B are shorted together by a **metal** jumper. The unit is shipped from the factory in this configuration. When Control Terminals A and B are shorted together, the optional motor overload relay is enabled, and the unit is configured as a motor starter.
4. Set the motor overload relay to the desired settings:
 - a. Adjust the trip current to the appropriate current for the motor load being powered. The trip rating is 120% of the dial setting.
 - b. Set the overload relay to auto or manual reset as desired. For auto reset, push and turn the reset button clockwise to the Auto position. The button will remain depressed.

⚠ WARNING! In this position the relay will reset automatically approximately two minutes after tripping, providing power to the load without warning.

- c. For manual reset, push and turn the reset button to the manual position. In this position, pushing the button

- d. resets the overload relay. Additional information on the motor protection unit is provided in Section 5, *Motor Overload Relay Information*.
- e. Connect input power to the unit from an appropriate single-phase circuit. See the Section 2, *Input Power Source Considerations*, for additional information.
5. Before energizing the input power, measure the source voltage. Phase-to-phase voltage must be within the input range of 187-260VAC, and the phase-to-ground voltage should be half this value.
6. Energize the unit before any loads are connected to the output and measure the output phase-to-phase voltages to ensure they are within the specified range. Because the three-phase output is delta-configured three-phase, the output phase-to-ground voltages will not be equal. T3-to-ground voltage will be higher than T1 or T2 to ground.
7. Turn the unit OFF by means of the input disconnect, lock and tag it, then wait at least 30 minutes for any internal charges to dissipate.
8. Connect the output wires to the output terminals. Torque the terminal screws to the values listed in Table 2 *Field Wiring Terminal Specifications*.
9. Close and latch the front cover.
10. Turn the unit ON from the disconnect switch. Power will be available to the load circuits after an approximately five to eight second delay. Check any three-phase motor loads for correct rotation. If the motor rotation is incorrect reverse any two of the three output power leads to that motor.
11. Note: A low power remote switch can be wired into the Control Terminals to control the unit and the associated motor load as described in the following section, *Remote ON/OFF Control*.

Remote ON/OFF Control

⚠ WARNING! When the converter is turned OFF using a remote switch on the Control Terminals, dangerous voltage is still present on the input lines, inside the enclosure and on certain output lines to ground. Never open the enclosure or perform maintenance on the unit and its connected loads when the input disconnect switch in the ON position.

When a low power remote switch is connected to the Control Terminals, the unit and any connected loads can be switched ON/OFF by a remote switch. **The remote switch must be rated at a minimum of 240 VAC, 0.5 amp.** A PT Series power supply configured with the Motor Starter option used to power a motor load with remote ON/OFF is illustrated in Figure 8:

Figure 8 Motor Starter with Remote ON/OFF

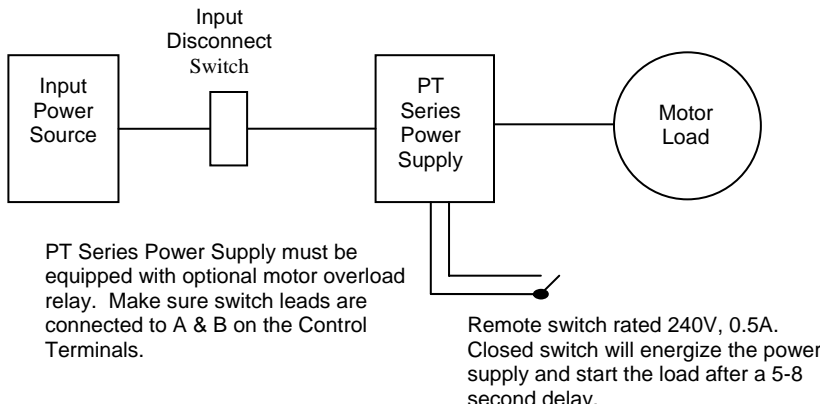

Follow this procedure when wiring a remote switch to control the unit:

1. Verify that no input power is connected to the unit by turning the input disconnect to OFF, then lock and tag it.
2. Open the front cover to gain access to the wiring terminals. See the Section 2, *Connecting to Field Wiring Terminals*, for a drawing illustrating the wiring terminals.
3. If the unit is equipped with the optional Motor Starter, it is shipped from the factory with a metal jumper connecting Control Terminals A and B.

CAUTION! The wire connecting A to C at the top of the Control Terminal is **NOT** a jumper, and should **NOT** be removed.

4. Verify that control terminals A and B are shorted together by a **metal** jumper. The unit is shipped from the factory in this configuration. When contacts A and B are shorted together the optional motor protection unit is enabled, and the unit is configured as a motor starter.

5. Remove the metal jumper and connect the remote switch leads to Control Terminals A and B. When operating, closing the remote switch will energize the unit and start the load after approximately a five to eight second delay. The control circuit should be rated for 240V, 0.5A. A 3A fuse labeled *F501* protects the remote switch circuit.
6. If the unit is equipped with the optional Motor Starter feature, the motor overload relay can be bypassed by connecting the switch leads to Control Terminals B and C. In this manner, the unit can operate in the power supply mode to power multiple loads, or loads that have their own integrated controls.

Section 4: OPERATION

Operation of a PT Series power supply is simple and straightforward after completion of installation and wiring.

ON/OFF Options

There are two ways to turn a PT Series power supply ON and OFF:

ON/OFF With Input Power Disconnect Switch

In most cases, the unit should be installed with a disconnect switch on the line side of the unit. When in the OFF position, this disconnect switch will break the connection between the unit and the input power source.

 **WARNING!** Make sure the input power disconnect switch is in the OFF position before opening the front cover to the unit. Opening the front cover with the switch in the ON position exposes the user to the risk of electric shock.

When the unit is energized, output power is provided to the load after a delay of approximately five to eight seconds.

ON/OFF With a Low Power Remote Switch

When Phase Perfect is configured with a remote ON/OFF switch on the Control Terminals, the input power disconnect switch is left in the ON position. When the remote switch connected to the Control Terminals is closed, the unit energizes, and output power is provided to the load after a delay of approximately five to eight seconds. When the input power is

ON, and the remote control switch is open, the unit is not energized and will not consume any power. No phase-to-phase voltage will be present on the output lines.

 **WARNING!** When the converter is turned OFF using a remote switch on the Control Terminals, dangerous voltage is still present on the input lines, inside the enclosure and on certain output lines to ground. Never open the enclosure or perform maintenance on the unit and its connected loads when the input disconnect switch in the ON position.

When either the input power disconnect switch is OFF, or the remote switch on the Control Terminals is open, the status LEDs will be off. If the unit is equipped with the optional text display, the status screen will be blank.

Status Indicators

The GREEN, YELLOW, and RED status LEDs are found on the control printed circuit board inside the enclosure, or are mounted on the front cover when the unit is equipped with optional EMI enclosure. The status lights provide information about the operating status of the unit, and provide useful troubleshooting information.

An optional text display status screen is also available on some models that provides 2 row, 32 character text messages for status indicators.

Three basic status LED indications are:

- **STEADY GREEN** status LED: Unit energized, normal operation
- **STEADY YELLOW** status LED: Unit overheated
- **FLASHING RED** status LED: Internal short in unit

Note: The red and yellow status lights may flash briefly when starting heavy loads. This is normal and can be ignored.

Different combinations of the status LEDs provide information about the operating status of the unit, and can be used in troubleshooting. A complete listing of status indicators is provided in the Section 6 *Status Indicators and Troubleshooting*.

When equipped with the optional Motor Starter feature, the unit provides motor over-current protection through a solid state motor overload relay. The motor overload relay provides a current adjustment range suitable for a wide motor horsepower range up to the capacity of the converter. The motor overload relay is enabled when the unit is used in the motor starter configuration by shorting Control Terminals A and B together. The overload relay should be disabled by shorting terminals B and C together when the unit is used in the power supply configuration.

The following points describe adjustment and features of the motor protection unit.

1. **TRIP CURRENT ADJUSTMENT BUTTON**—Used to adjust the current trip limit for protecting single-motor loads. To adjust the trip current, turn the dial until the desired current is aligned with the pointer. The trip rating is 120% of the dial setting. Consult motor specifications for appropriate current limits.
2. **MANUAL/AUTO RESET BUTTON**—Used to control automatic and manual reset features of the overload relay, and to reset the motor protection unit if it trips out. The unit is shipped from the factory in the manual mode. Automatic reset of the overload relay is often desirable for applications such as unattended pumps. Manual reset is typically used when the converter and load are readily accessible.
 - a. For auto reset, push and turn the reset button clockwise to the Auto position. The button will remain in the IN position. The unit will reset automatically approximately two minutes after tripping.
 **WARNING! Do not use the automatic reset mode in applications where unexpected automatic restart of the motor can cause injury to persons or damage to equipment.**
 - b. For manual reset push and turn the reset button to the Manual position. In this position the button must be manually pushed to reset the overload relay.
 - c. To manually trip the overload relay, push and turn the button counterclockwise to the trip position. Releasing the button reverts the unit to the manual position.
 - d. To reset the overload relay push the button.
3. **TEST BUTTON**—Will turn the unit off and power to the load when pushed.
TRIP INDICATOR WINDOW—A yellow indicator will be visible on the relay if it has tripped due to an overload condition. The overload

4. relay can be reset by pushing the manual/auto reset button IN when the button is in the manual position.
5. **OUTPUT POWER SECURE SCREWS**—Used to secure power wires in place between the motor protection unit and the load.
6. **INPUT POWER SECURE SCREWS**—Used to secure input power wires from the PT Series internal electronics to the overload relay in place. Factory pre-installed wires at this location should not be removed or altered.
7. **CONTACT MODE SCREWS**—Used to secure wires to configure the contact mode of the overload relays. **Wires connected to the NC contacts are pre-wired at the factory, and should not be removed.**

More detailed information on the motor overload relay is available in the overload relay operation and installation manual which is enclosed with this manual. For further support on the motor overload relay, contact the Field Support Manager at Phase Technologies, (605) 343-7934.

Section 6: STATUS INDICATORS AND TROUBLESHOOTING

This section provides troubleshooting information for potential system problems.

 **WARNING!** In some instances, such as overheating, the unit will shut down, then automatically restart when conditions allow. Always disconnect input power from the unit and wait for internal electrical charges to dissipate before performing service on the unit or its connected loads.

General Troubleshooting Tips

After the system is properly connected to input power, turn the unit ON with the disconnect switch and/or input circuit breaker. It is always advisable to check the operating status of the converter before connecting any loads to the output.

If the unit fails to energize, and all status indicators are off, check the following:

1. Verify that the appropriate circuit breaker in the electrical source distribution panel is set ON and is properly sized.

2. Check the control circuit fuse, labeled *F501*, located on the panel inside the unit enclosure. If necessary, replace with appropriate 3A fuse.
3. Verify that the metal jumper on the Control Terminal is connected either A to B for motor starter configuration, or B to C for power supply configuration. The unit will not operate unless the metal jumper or control circuit wires are connected to the appropriate control terminals. **CAUTION!** The wire connecting A to C at the top of the Control Terminal is **NOT** a jumper, and should **NOT** be removed.

If the Motor Starter feature is enabled and the unit will not energize, it is possible that the motor overload relay has tripped:

1. Check the TRIP INDICATOR WINDOW on the motor protection unit to see if it has tripped. If tripped, push the AUTO/MANUAL RESET button on the motor protection unit.
2. Verify that the overload relay current limit is appropriately set for the load.

Refer to the following Status Indicator Table for additional troubleshooting tips.

Status Indicators

The status lights and the optional text status screen provide are useful for detecting and diagnosing system problems. The Status Indicator Tables provide a list of status indicators, followed by a description and potential causes of the problem.

The GREEN, YELLOW, and RED status LEDs are found on the control printed circuit board inside the enclosure, or are mounted on the front cover when the unit is equipped with optional EMI enclosure. The status lights provide information about the operating status of the unit, and provide useful troubleshooting information.

An optional text display status screen mounted in the door of the enclosure is also available on some models that provides 2 row, 32 character text messages for status indicators.

Table 4 Status Indicators

LED INDICATOR	TEXT INDICATOR	COMMENTS AND TROUBLESHOOTING TIPS	
STEADY GREEN	SYSTEM ON NORMAL		
FLASHING GREEN	STARTING		
STEADY YELLOW	STOPPED OVERTEMP WAIT FOR RESTART	Check for faulty fan, or ventilation opening obstructions. Reduce ambient temperature.	2
FLASHING GREEN STEADY YELLOW	DEFECTIVE TEMP SENSOR	Failed temp sensor (TM circuit board) or loose connection to TM circuit board	3
STEADY RED	C1 VOLTAGE LOW	Check charging circuit fuse (F701), relay and diode. Possible failed bus capacitor on VPOS	2
STEADY GREEN STEADY YELLOW	C2 VOLTAGE LOW	Check charging circuit fuse (F701), relay and diode. Possible failed bus capacitor on VNEG	2
FLASHING YELLOW FLASHING RED	C1 OVER VOLTAGE	Possible heavy power regeneration from load. Possible voltage sensing problem on EA200 circuit board	3
FLASHING YELLOW	C2 OVER VOLTAGE	Possible heavy power regeneration from load. Possible voltage sensing problem on EA200 circuit board	3
STEADY GREEN FLASHING RED	POSSIBLE SHORT C1	Internal fault possible, contact factory	3
FLASHING GREEN STEADY RED	POSSIBLE SHORT C2	Internal fault possible, contact factory	3
FLASHING RED	IGBT FAULT INPUT MODULE	Possible failed IGBT or PDR500 circuit board on input module	3
FLASHING GREEN FLASHING RED	IGBT FAULT OUTPUT MODULE	Possible failed IGBT or PDR500 circuit board on output module	3
STEADY YELLOW STEADY RED	INPUT FREQUENCY OUT OF RANGE	Input frequency must be 46-64 Hz. Generator source must be stable. Possible voltage distortion in source power.	2
STEADY YELLOW FLASHING RED	LOW INPUT V AUTO RESTART	Increase input voltage to specified input range if possible. See Note 1.	1
FLASHING YELLOW STEADY RED	LOW INPUT V AUTO RESTART 1HR	Increase input voltage to specified input range if possible. See Note 1.	1
STEADY GREEN STEADY RED	LOW INPUT V AUTO RESTART 10S	Increase input voltage to specified input range if possible. See Note 1.	1
STEADY GREEN STEADY YELLOW STEADY RED	HIGH INPUT V AUTO RESTART	Decrease input voltage to specified input range if possible. See Note 1.	1

LED INDICATOR	TEXT INDICATOR	COMMENTS AND TROUBLESHOOTING TIPS	
STEADY GREEN STEADY YELLOW FLASHING RED	HIGH INPUT V AUTO RESTART 1HR	Decrease input voltage to specified input range if possible. See Note 1.	1
STEADY GREEN FLASHING YELLOW	HIGH INPUT V AUTO RESTART 10S	Decrease input voltage to specified input range if possible. See Note 1.	1
FLASHING GREEN STEADY YELLOW STEADY RED	OVERCURRENT INPUT 10S	Input current exceeded steady state maximum. Reduce load or increase input voltage if possible.	3
FLASHING GREEN FLASHING YELLOW STEADY RED	OVERCURRENT OUTPUT 4S	Output current exceeded momentary maximum. Reduce load or increase input voltage if possible.	3
FLASHING GREEN FLASHING YELLOW FLASHING RED	OVERCURRENT OUTPUT 10S	Output current exceeded steady state maximum. Reduce load or increase input voltage if possible.	3
FLASHING GREEN STEADY YELLOW FLASHING RED	SYSTEM INTERRUPT CYCLE PWR OFF ON	Possible software code hang-up. Reboot by cycling input power OFF ON.	3
FLASHING GREEN FLASHING YELLOW	VOUT SENSE WIRE IS LOOSE	The output sense wire may be off or loose The output voltage may be momentarily too low	3

Note 1: For high and low input voltage trip, the unit will attempt to restart after a 10 sec. delay, followed by another 10 sec. restart delay. If the unit does not successfully start on the second try, the cycle will be repeated after a 1 hr. delay. The restart cycle can be cancelled by cycling input power OFF ON.

Note 2:  **WARNING! Unit will restart automatically when condition returns to normal.**

Note 3: Unit will not automatically restart. Cycle input power OFF ON to restart.

For assistance, contact the Field Support Manager at Phase Technologies, (605) 343-7934.

Section 7: FEATURES AND SPECIFICATIONS

Important Features

- Clean, balanced power under all load conditions for even the most demanding applications
- Electronic power factor correction on the input module for efficient, utility-friendly operation
- IEEE 519 compliant
- Sinusoidal output voltage allows operation of all types of sensitive equipment
- Protects operated equipment from over-voltage, under-voltage and other adverse events
- 97% efficiency typical
- Simple to configure and install
- Optional Motor Starter feature includes starter and overload protection for single motor loads
- Remote ON/OFF switching capability standard on all models
- EMI filter options available to reduce both conducted and emitted noise
- Optional plasma display for 2 line, 32 character text display of status indicators and trouble shooting codes
- New compact design in wall mounted enclosures
- Outdoor rainproof enclosures available
- Clean power fed back to power grid under regenerative load conditions

Table 5 Specifications

MODEL	PT3160 (2 x 80A units)	PT3110 (2 x 55A units)	PT355	PT330	PT380
Input	1-phase, AC 187-260V 50/60 Hz 285A	1-phase, AC 187-260V 50/60 Hz 196A	1-phase, AC 187-260V 50/60 Hz 98A	1-phase, AC 187-260V 50/60 Hz 54A	1-phase, AC 187-260V 50/60 Hz 143A
Output*	3-phase, AC 187-260V 50/60 Hz 160A	3-phase, AC 187-260V 50/60 Hz 110A	3-phase, AC 187-260V 50/60 Hz 55A	3-phase, AC 187-260V 50/60 Hz 30A	3-phase, AC 187-260V 50/60 Hz 80A
Rated output (at 240V)	66.4 KVA	45.7 KVA	22.9 KVA	12.5 KVA	33.2 KVA

General Specifications:

- Enclosure: Type 1 indoor or Type 3R rain proof, wall mount, powder coated steel or powder coated aluminum
- Ambient temperature operating range: -10C to +40C
- Storage temperature range: -20C to +60C
- Typical efficiency at full load: 97%

Table 6 Fuses

FUSE ID	FUSE RATING	COMMENTS
F1	2 A, slow blow	Located on PCB PWR600
F2	2 A, slow blow	Located on PCB PWR600
F3	3 A, fast blow	Located on PCB PWR600
F501	3 A, fast blow	Panel mounted, protects CONTROL circuit
F701	12 A, slow blow	Panel mounted, protects DC bus charging circuit